

VIEW B

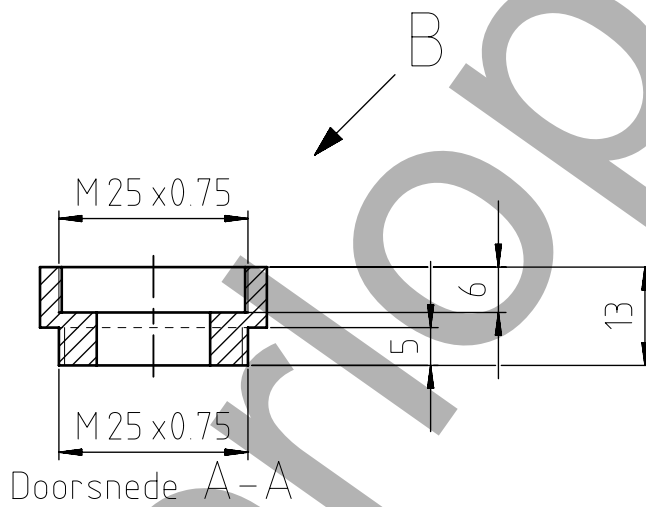

08	1	Isolatiemoer	POM (Zwart)			
Item	Qty	Partname	Material	Partnumber/Remarks		
Physics of Cellular Interactions 01 K2-Varia					Date	Name
				DRN	01-07-2019	MV
				PRD	01-07-2019	MV
scale: 1:1			 Dim.in mm	General tolerances unless otherwise specified ISO-2768-fH-E	Geometrical tolerances unless otherwise specified ISO-8015-E	Surface roughness of machined surfaces unless otherwise specified 3,2 Ra (maximum standard) 1,6 Ra (fitting typical)
					Size A4	Partnumber: CELIN-01-00-08
Number of sheets: 1 of 1						

This drawing may not be used for commercial purposes without written authorisation